

User Manual



Water Cooling Unit AnyCool-100

MEGMEET

Water Cooling Unit

User Manual

Model: AnyCool-100

Version: V1.0

Code: R33010847

Shenzhen Megmeet Welding Technology Co., Ltd. provide customers with a comprehensive technical support. Users can contact with local distributors or Megmeet Service Center in Shenzhen headquarters.

Shenzhen Megmeet Welding Technology Co.,Ltd

Address:3rd Floor, Block C Unisplendour Information Harbor,Langshan Road, Shenzhen, Guangdong, 518057, China

www.megmeet.com

www.megmeet-welding.com

Tel:+86-755-8660-0555

E-mail:welding@megmeet.com

Preface

Thank you for purchasing water cooling unit AnyCool-100 (hereinafter referred to as water cooler) produced by Shenzhen Megmeet Welding Technology Co., Ltd.

This manual stipulates installation guidance, operation and routine maintenance precautions. Please read this user manual carefully before installing, so as to ensure correct installation and operation, and give full play to its superior performance. Please keep properly and send it to the user.

MEGMEET conducts product development and innovation continuously. If the contents, parameters and pictures in this user manual are inconsistent with the real object, the actual product shall prevail. It is subject to change without prior notice. The Company has the right of final interpretation of user manual.

Safety Precautions

Safety Definition

In order to use the water cooler safely and correctly, and prevent harm to you or others and property damage, this manual adopts various warning signs for instructions. Please follow strictly after full understanding.

The following signs are classified according to the degree of danger or damage, and warning is given.



Please operate as required, otherwise it may result in death or serious injury.



Please operate as required, otherwise it may result in moderate or minor injury or damage to property.

Installation precautions



Danger

- Please install it on an incombustible object, otherwise it may result in fire disaster.
- Do not keep combustibles nearby, otherwise it may result in fire disaster.
- Do not install in an environment with explosive gases, otherwise it may result in explosion.
- Wiring must be done by professionals, otherwise it may result in electric shock.
- Ensure that the input power is completely disconnected before wiring. Otherwise it may result in electric shock.
- Install the shell before powering on the device. Otherwise it may result in electric shock.
- Do not touch the terminal with your hands when the device is electrified. Otherwise it may result in electric shock.
- Maintenance should be performed 5 minutes after disconnecting the power supply. At this time, the welding power indicator is off. Confirm that the positive and negative bus voltage is below 36V. Otherwise it may result in electric shock.
- Parts must be replaced by a professional. Do not leave thread ends or metal objects in the machine. Otherwise it may result in fire disaster.
- Cables must be wrapped with insulating tapes and aren't allowed to expose. Otherwise it may result in electric shock.



Caution

- Do not operate the water cooler in the process of handling. Otherwise falling may result in personal injury or property damage.
- Do not install near water pipes or other places where water droplets may splash. Otherwise it may result in property damage.

- Do not drop foreign objects such as screws, gaskets and metal rods into the water cooler. Otherwise it may result in fire disaster and property damage.
- Do not install the water cooler if it has damage or incomplete parts. Otherwise it may result in fire disaster and personal injury.

Precautions for Use



Danger

- Only personnel with safe operation knowledge and welding skill can perform welding to ensure safety.
- The water cooler shall not be used for any purpose other than connecting with Megmeet welding power source.
- Installation, debugging and maintenance of water cooler must be performed by professionals. Do not let anyone near the device after its shell has been removed.
- The water cooler is only suitable for the water-cooled welding torch of welding power source. Do not use it for any purpose other than water-cooling type.
- Do not touch electrified areas. Otherwise it may result in electric shock.
- Do not adopt the cables with insufficient sectional area, exposed conductors, or damaged cables.
- Do not remove the device enclosures during use.
- Please use undamaged gloves with good insulation.
- Pay attention to safety protection in high-place operation.
- Power off welding power source and distribution box when the machine isn't used.
- Do not weld near combustible materials.
- Please put a fire extinguisher near the welding operation site.
- Keep hands, fingers, hair and clothes away from fans and motors.



Caution

- The requirements of operational environment are as follows:
Scope of working temperature: $-20^{\circ}\text{C} \sim +40^{\circ}\text{C}$
Scope of transportation and storage temperature: $-40^{\circ}\text{C} \sim +60^{\circ}\text{C}$
There is no obvious mechanical vibration and mechanical shock in the working environment.
The dust, metallic dust and corrosive gases in ambient air don't exceed normal content.
- Splashes from welding operation and iron powder from polishing operation may enter the water cooler, so the water cooler must be away from the operation site.
- If any spatter or iron powder enters the water cooler, please turn off the power and remove it with a blower.
- Please remove the water in water cooler before handling or moving it.

Precautions for Scrapping

When scrapping the water cooler, please pay attention to:

1. The electrolytic capacitor on the water pump may explode in the process of incineration.
2. Toxic gas will generate when plastic parts are burned.
3. Please handle it as industrial solid waste.

Contents

Chapter 1 Product Overview	1
1.1 Product Introduction	1
1.2 Dimension and Net Weight	1
1.3 Technical Specification	2
Chapter 2 Installation and Wiring	3
2.1 Unpack for Inspection	3
2.2 Installation Requirements	3
2.3 Installation of Water Cooler	3
2.4 Electrical Connection	5
Chapter 3 Function Description and Operation	7
3.1 Function Description	7
3.2 Water Cooler Operation	7
3.3 Water Injection/Drainage	8
3.4 Filter (optional)	8
3.5 About Coolant	9
Chapter 4 Maintenance and Troubleshooting	10
4.1 Routine Inspection	10
4.2 Regular Inspection and Maintenance	10
4.3 Troubleshooting	11
4.4 After-sales Service	11
Appendix I Structure Diagram	13

Chapter 1 Product Overview

1.1 Product introduction

AnyCool-100 is original water cooler of MEGMEET welding power source, which is used for cooling-water welding torch and controlled by the microprocessor of welding power source.

- It is suitable for Artsen Plus series, Artsen series, Ehave series machines.
- No need of external power supply, it is directly powered by welding power source, with stable cooling capacity.
- It can store coolant (pure water or all-organic antifreeze) , no need of external water pipe.
- It is equipped with a water flow sensor, which is easy to remind water shortage or water pipe blocking, reducing the risk of gun damage.
- The filter mesh is set in the water inlet of water cooler, which can be directly removed for cleaning.
- Simple operation and easy maintenance

※**Tips:** This product is equipped with a water flow sensor, which is only used as the reminder function for water shortage or pipe blocking. Comprehensive factors such as the long-term high-power welding, ultra-long water loop, and improper selection of welding torch will greatly impact the cooling effect. It is recommended to use the cooling water cooler of other brand with high-power compressor.

1.2 Dimension and Net Weight

Dimension and net weight of water cooler are described in this section, as shown in Table 1-1.

Table 1-1 Dimension table of water cooler

Name of Product	Model	Dimension (Length × width × height) mm	Net weight (kg)
Water Cooler	AnyCool-100	730×300×270	15

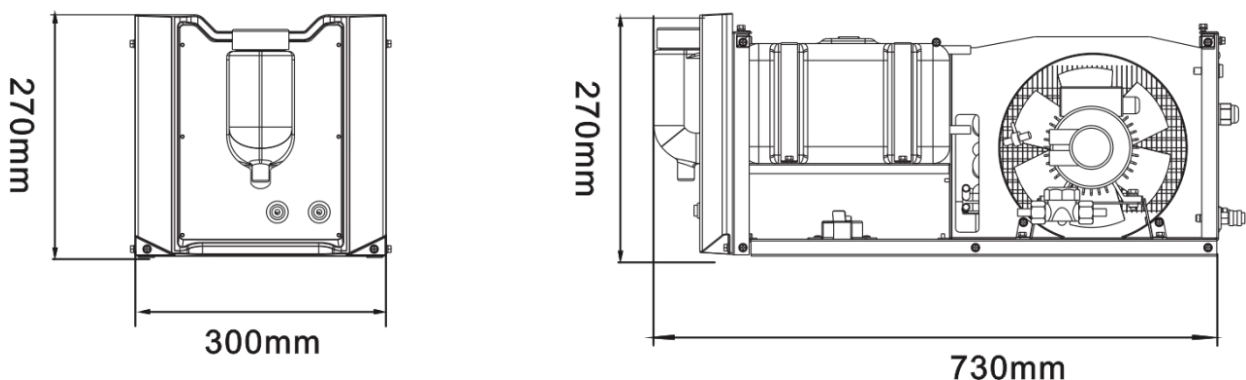

Figure 1-1 Dimension Drawing of Water Cooler

1.3 Technical Specification

Table 1-2 Technical Specification of Water Cooler

AnyCool-100	
Input power	400Vac / 50/60Hz
Power of water pump	272W
Cooling power	1.7KW
Maximum start-up pressure	0.38MPa
Coolant	Pure water (environment temperature > 0°C)/all-organic coolant
Technical Specification	MAX 10L
EMC Classification	IEC 60974:10 (Class A)

Chapter 2 Installation and Wiring

Requirements, operation procedures, and precautions for water cooler installation are described in this chapter.

2.1 Unpack for Inspection

1. Before unpacking, please confirm whether the outer packing is intact.
2. After unpacking, please confirm whether all parts of welding power source are complete and whether the model are consistent with the contract order.

In case of missing or wrong parts, please contact with Megmeet in time.

2.2 Installation Requirements

Environmental requirements

- When selecting an installation environment, pay attention to the following matters:
- It must be installed in a well-ventilated premise with the vibration of less than 5.9 m/s^2 (0.6g).
- Avoid installation in the dusty places with metal powders.
- It is prohibited to install in places with corrosive or explosive gases.
- The ambient temperature must be -20°C to $+40^\circ\text{C}$. When temperature is more than 40°C , external forced heat dissipation or derating is required.
- Humidity shall be less than 95% without condensation of water drops.

For special installation requirements, please consult and confirm with Megmeet.

Requirements of installation space

Welding power source shall be at least 20cm away from the wall. When multiple devices are placed side by side, the interval is more than 30cm. It is recommended to place the welding source according to the space reserved in Table 2-1.

Table 2-1 Reserve space for water cooler installation

	Front	Left side	Right side	Back side
Reserve space	$\geq 20\text{cm}$	$\geq 20\text{cm}$	$\geq 20\text{cm}$	$\geq 20\text{cm}$

2.3 Installation of Water Cooler

Water cooler can be installed on trolley together with the welding power source and wire feeder, which is easy to move and operate. It can also be placed separately beside the welding power source, which is the same as the combined installation.

Step

1. Place the water cooler on trolley and fix with screws and bolts, as shown in Figure 2-1;
2. Install the welding power source and wire feeder on the water cooler.

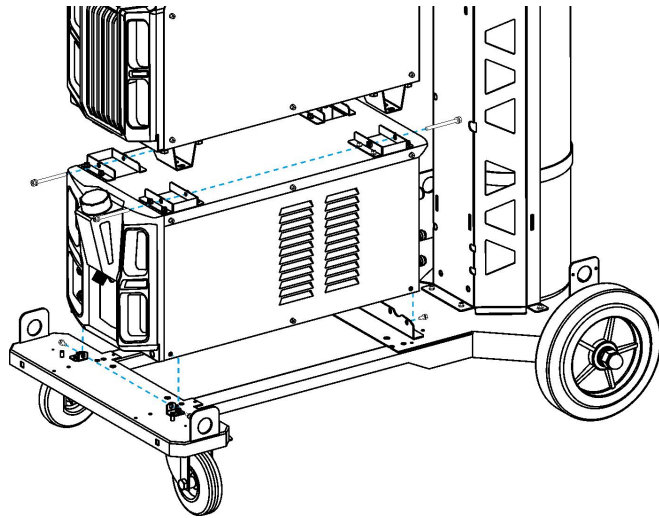

Figure 2-1 water cooler installation diagram

2.4 Electrical connection

Step

● Power Connection of Water Cooler

As shown in Figure 2-2.

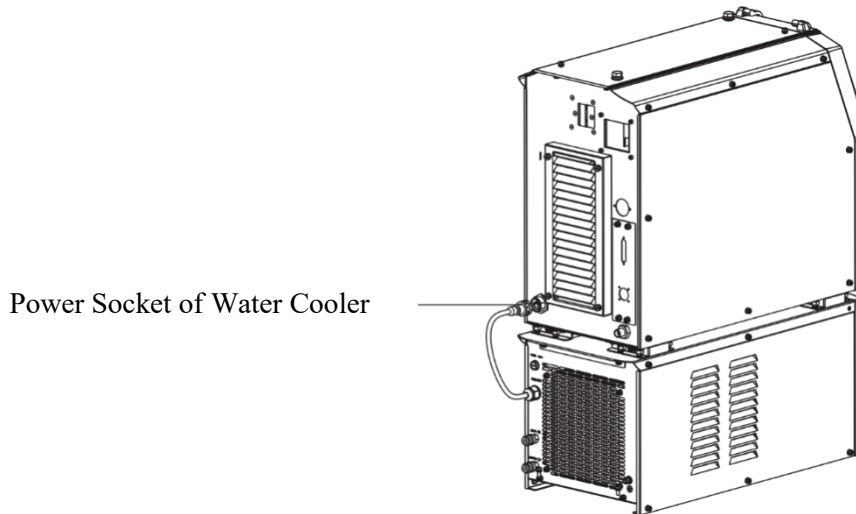

Figure 2-2 Power connection diagram of water cooler

● Pipe Connection of Water Cooler

Step

Insert water inlet and outlet pipes of combined cable into the water inlet and outlet pipes of water cooler, as shown in Figure 2-3.

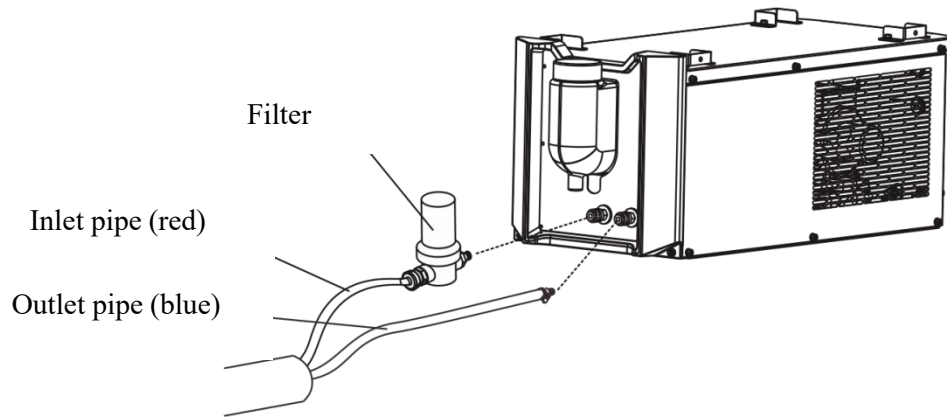

Figure 2-3 Pipe connection diagram of water cooler



Safety Warning

1. Water cooler is powered by high voltage 380VAC and is powered by welding power source. Please turn off the welding power source in the process of wiring. Otherwise, it may result in electric shock.
2. Water cooling function should be activated when the water cooler is used. Refer to manual of welding power source for specific operation;
3. Water cooler is equipped with a water flow detector. The water flow switch detection function should be activated. Refer to the manual of welding power source for specific operation;
4. Please use pure water or all-organic antifreeze. Otherwise, it may damage the water cooler;
5. The cooling liquid in kettle must be kept above the lowest water level scale.

Chapter 3 Function Description and Operation

3.1 Function description

Functions of water cooler parts are shown in Figure 3-1.

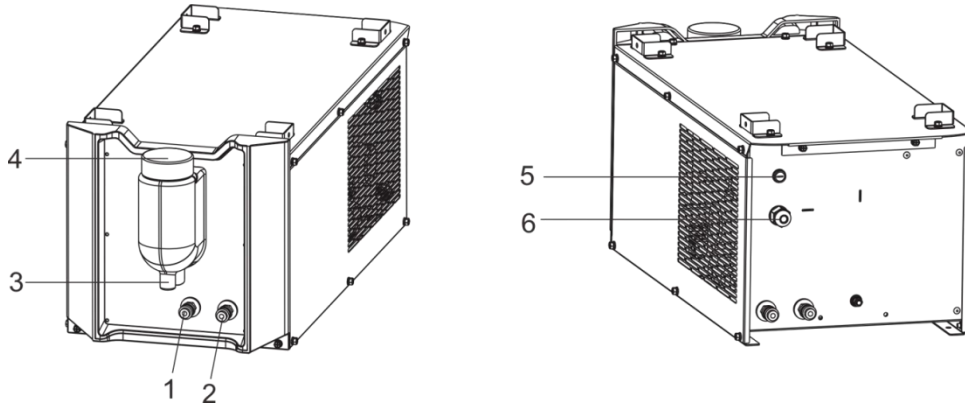

Figure 3-1 Water cooler part drawing

Table 3-1 Function description of water cooler parts

No.	Serial number and name	Function description of each part
1	Water outlet (blue)	Used in the connection of cooling water outlet pipe
2	Water inlet (red)	Used in the connection of cooling water inlet pipe
3	Drain hole	For discharge of coolant
4	Charging hole	For coolant injection
5	Safety switch	For over-current protection of water pump, 6.3A
6	Main power and Control cable	For the connection with welding power source

3.2 Water Cooler Operation

Step

1. Inject coolant into the charging hole of water cooler, and observe whether the cooling water reaches the standard scale;
2. After power is on, water pump starts to run, and the cooling water circulates in the welding torch;
3. Unplug water inlet pipe from \water cooler (red), and drain air from the pipe to ensure that the circulating water route doesn't contain bubbles to improve cooling efficiency;
4. After welding stops, water pump will continue to work for 3 minutes and then automatically stop running.



Tips

1. If water cooler is used for the first time without water injection, water pump may be damaged;
2. When using water cooler, it is necessary to activate the water cooling function, check the water cooler on front panel. After self-inspection, water cooler can be used normally.

3.3 Water Injection/Drainage

Step

1. Prepare 10 L coolant, open top cover of water cooler counterclockwise, inject water and tighten tank cover;
2. When draining, open the lid from the bottom of water cooler. After draining, tighten it, as shown in figure 3-2.

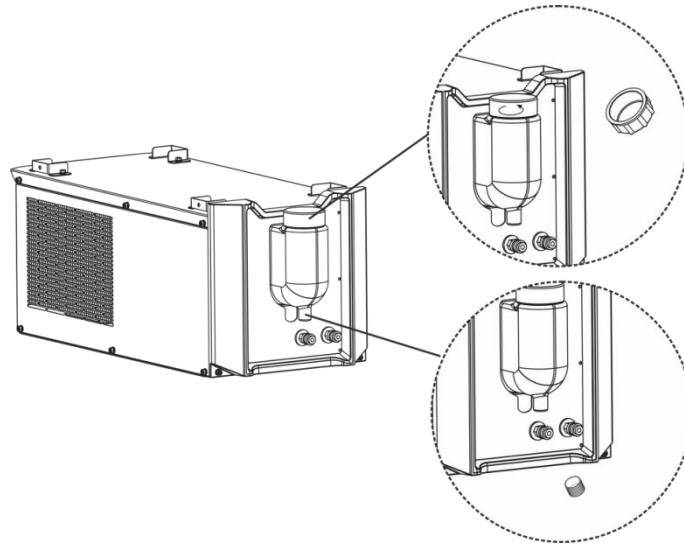

Figure 3-2 Water Injection/Drainage Diagram



Safety Warning

1. Before re-filling water, turn off the switch on both of power switch and distribution box;
2. Please place filter element of water cooler before injecting coolant;
3. If coolant is found to leak into the welding power source or water cooler, there may be a fault, and the water drops must be wiped immediately.

3.4 Filter (Optional)

Connect one end of the filter to water cooler, and connect the other end to the inlet pipe, as shown in Figure 3-3.

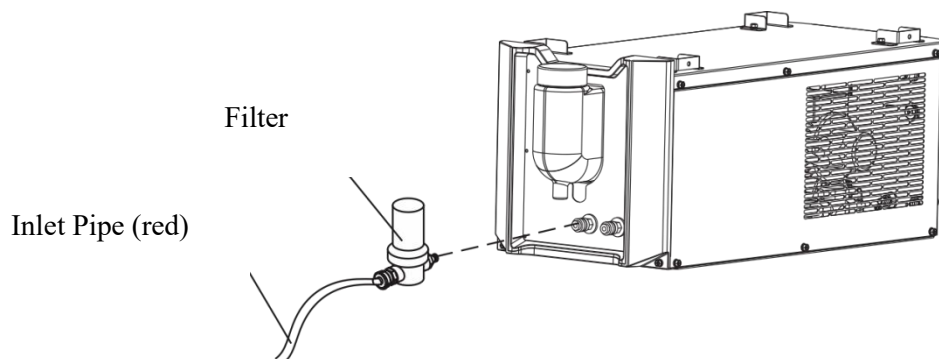

Figure 3-3 Filter Connection Diagram

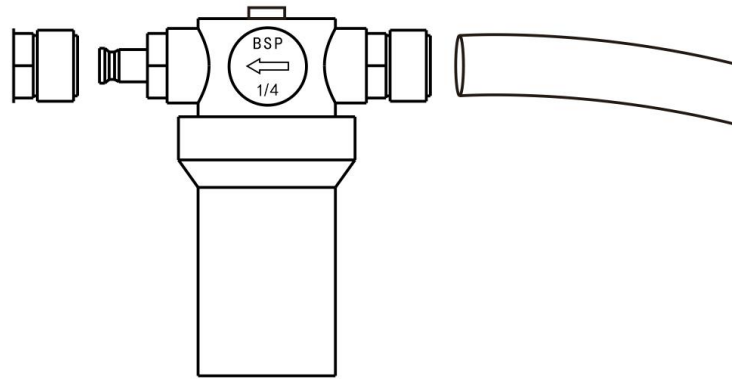

Figure 3-4 Schematic Diagram of Filter Connection Direction



Notes

1. Filter is optional part. Please select it as required;
2. Please connect the filter according to the arrow direction. Do not connect backwards;
3. The filter must be connected to inlet pipe (red), and it isn't allowed to connect to outlet pipe (blue).

3.5 About Coolant

- Pure Water

1. Pure water can be used as coolant, which shall be replaced two to four times a month. Sewage and water with foreign objects can result in faults. Do not use sewage, groundwater, river water and other water with microorganisms;

2. Ambient temperature $> 0^{\circ}\text{C}$. Use pure water or distilled water (PH 7-8 neutral).

- All-organic antifreeze

- **In the season or application environment where cooling water may freeze, the ambient temperature is less than or equal to 0°C , please be sure to use an all-organic antifreeze (acid-base pH value is 7-8 neutral), and it is forbidden to mix different antifreezes (Please use glycol antifreeze. Other salts and alcohol antifreeze may induce abnormal mechanical properties of product. It needs to avoid damage to cooling equipment.).**

- Handle with tank sediment in time.

Please clean the water cooler and replace the coolant regularly to avoid water cooler to produce coolant sediment.

Chapter 4 Maintenance and Troubleshooting

4.1 Routine Inspection



Safety Warning

1. Routine inspection must be conducted after turning off power supply of user's distribution box and the power supply of this device to avoid personal injuries such as electric shock and burn. (Except for visual inspection that does not require contact with electrical conductors)
2. When water cooler hasn't been used for a long time, please drain the liquid in it. Use the high-pressure gas to dry the residual liquid in the kettle, radiator and water pump.

Table 4-1 Routine inspection contents of water cooler

Item	Main inspection points	Notes
Earth cable	Check whether the safety earth cables fall off, including work-piece power earthing cables, welding power earthing cables.	In case of nonconformity, tighten or replace relevant parts.
Water level and input flow	Check water level and input flow. When the water level is below the minimum (MIN) line, it is necessary to refill liquid.	When water is insufficient, it is necessary to inject water in time.
Coolant	Check whether there are leaks in the cooling pipes.	In case of leaks, replace the cooling water pipe in time.
Liquid in water cooler	Check whether the liquid in the water cooler is clear and has no impurities.	Replace the liquid in time when there is dirt.

4.2 Regular Inspection and Maintenance

Table 4-2 Contents of regular inspection and maintenance

No.	Item	Operation and precautions	Maintenance cycle
1	Dust	Remove the upper cover, dry the radiator in tank to prevent air blocking from affecting the heat dissipation.	Once per Quarter
2	Pure water/All-organic antifreeze	Pure water or distilled water is required for the areas where don't freeze. The acid and alkali components may corrode the radiator and water seal, so they shall be replaced once every six months.	Once per half a year
		All-organic antifreeze must be used in frozen areas to avoid freezing and cracking of cooling copper pipes; antifreeze must be carefully selected and replaced once every six months because antifreeze with acid and alkali components will result in corrode the radiator and water seal parts.	Once per half a year Once per week
3	Water loop inspection	The coolant in kettle must be kept above the minimum water level, and water pipe in water loop isn't obviously bent or blocked to avoid the damage of water seal caused by overheating of pump dry grinding.	Long-term inspection
4	Filter maintenance	Remove filter element and clean.	Once per week
5	Clean water cooler regularly	Drain the coolant from water cooler, use high pressure air rifle to clean water loop, then inject pure water, let tank run for 15 minutes to discharge the pure water, and inject all-organic antifreeze.	Once per quarter

6	Long-term storage without use	Clean according to the point 4 above (storage without injecting any liquid), and store water cooler in a dry warehouse.	Not used for more than 15 days
---	-------------------------------	---	--------------------------------



Safety Warning

1. Regular inspection must be performed by professionals to ensure safety;
2. Regular inspection must be conducted after turning off the power supply of user's distribution box and the power supply of this device to avoid personal injuries such as electric shock and burn.
3. Inspection is conducted 5 minutes after welding power source is powered off due to capacitor discharge.

4.3 Troubleshooting

If \water cooler has any abnormality or fault, check the fault according to the following table. If it cannot be repaired, please contact with local dealer or Megmeet service team.

Table 4-3 Troubleshooting and countermeasures of water cooler

No.	Failure Alarm	Reasons	Countermeasures
1	E61	Liquid in water cooler doesn't flow. Coolant in water cooler is below the lowest water level (MIN).	Check water circulation, and refill fluid if necessary.
		Water pump contains air without water. The water pipe is blocked.	1. Please remove red water return pipe, detect the water flow, and wait patiently for the air to drain out so that the pump can run normally. 2. If water flow is too small, it is necessary to unclog all blockages of water pipe.
		Coolant overflows from cooling device. Liquid overflows from the pipe joint of pump. The damage, corrosion or aging damage of water pipe. The mixture of different coolants results in the corrosion of water pipe.	1. If any components are damaged and cannot be repaired, please replace them, such as water pump, radiator. 2. Replace water pipe. 3. Clean the water bucket and replace the damaged parts. Do not mix coolants.



Tips

Please ensure that welding power source has turned on the water cooler switch and water flow switch, and keep ON state. OFF represents cooling function is disabled, and ON represents cooling function is enabled.

4.4 After-sales Service

- Warranty Card

Each unit has a warranty card. Please fill in the relevant content on the warranty card.
Please read the warranty card carefully and keep it properly.

- Maintenance

User shall check according to fault codes and countermeasures in the user manual of welding power source, troubleshooting the fault or recording the fault information.
Please contact your local dealer in case of component repair or replacement. Please use parts and

components provided by MEGMEET .

Warranty period of this product is one year, starting from the warranty card or purchase invoice.
Abnormal use and artificial damage isn't included in the free warranty coverage.

.

Appendix 1 Structure Diagram

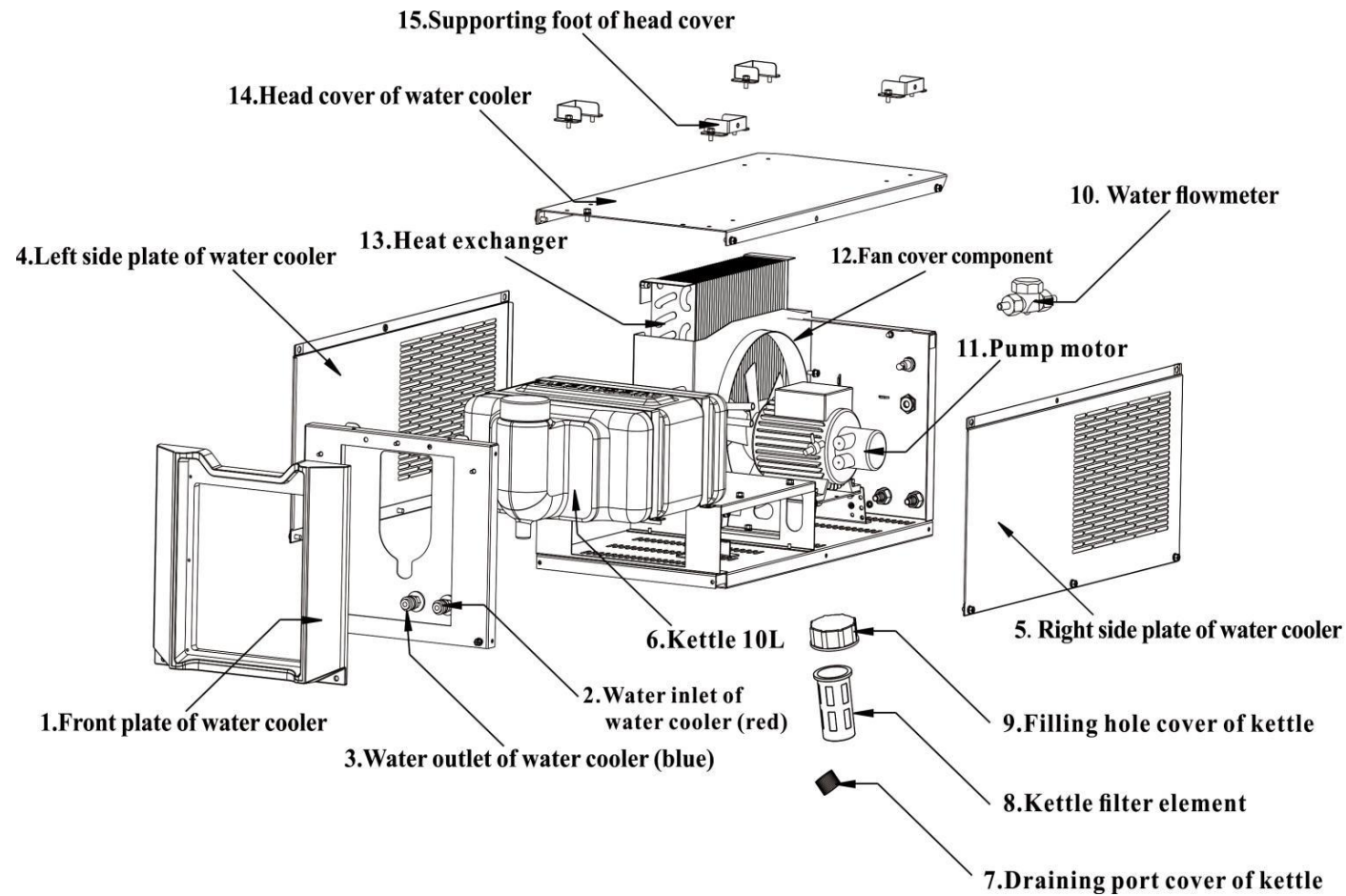

Material name	Code
1.Front plate of water cooler	R29060702
2. Water inlet of water cooler (red)	R29060704
3. Water outlet of water cooler (blue)	R29060703
4.Left side plate of water cooler	R29241775
5.Right side plate of water cooler	R29241774
6.Kettle 10L	R29131324
7.Draining port cover of kettle	R29131325
8.Kettle filter element	R29131327
9.Filling hole cover of kettle	R29131326
10-1. Water flowmeter	R34090013
10-2.Nylon pagoda-shaped connector	R29131167
11-1. Pump motor MCUP-65/380V	R36011400
11-2.Fan blade 200mm	R36011401
12.Fan cover component	R29242139
13.Heat exchanger 30*18cm	R29131328
14.Head cover of water cooler	R29242140
15.Supporting foot of head cover	R29242141

Figure 1 Structure Diagram

MEGMEET

Water Cooler Warranty Card

Name of User :	
Detailed address:	
Zip code:	Contact person:
Tel.:	Fax:
Machine model:	
Power:	Machine No.:
Contract No.:	Date of purchase:
Service Team:	
Contact person:	Tel.:
Maintenance personnel:	Tel.:
Date of maintenance:	
User evaluation of service quality: <input type="checkbox"/> Good <input type="checkbox"/> Relatively good <input type="checkbox"/> General <input type="checkbox"/> Poor Other opinions: User's signature: DD/MM/YYYY	
Return visit record of Customer Service Center: <input type="checkbox"/> Telephone follow-up <input type="checkbox"/> Letter follow-up Other Signature of technical support engineer: DD/MM/YYYY	

Notes: This card is invalid when the user cannot be interviewed.

MEGMEET

Water Cooler Warranty Card

Name of User:	
Detailed address:	
Zip code:	Contact person:
Tel.:	Fax:
Machine model:	
Power:	Machine No.:
Contract No.:	Date of purchase:
Service Team:	
Contact person:	Tel.:
Maintenance personnel:	Tel.:
Date of maintenance:	
User evaluation of service quality: <input type="checkbox"/> Good <input type="checkbox"/> Relatively good <input type="checkbox"/> General <input type="checkbox"/> Poor Other opinions: User's signature: DD/MM/YYYY	
Return visit record of Customer Service Center: <input type="checkbox"/> Telephone follow-up <input type="checkbox"/> Letter follow-up Other Signature of technical support engineer: DD/MM/YYYY	

Notes: This card is invalid when the user cannot be interviewed.

User Notes

1. Warranty scope refers to the body of water cooler.
2. The warranty period is 12 months under the normal use of the warranty period, and water cooler is faulty or damaged. We repair it free of charge.
3. The start time of warranty period is the manufacture date of water cooler. The code number is the only basis to judge the warranty period. The equipment without tank code is treated out of warranty.
 - 4. If any of the following conditions occur during warranty period, a certain maintenance fee will be charged:
 - Failure of water tank caused by not operating according to the user manual;
 - The water cooler is caused by fire, flood, voltage abnormality, etc.;
 - Damage caused when water tank is used for abnormal functions.
5. Service fee is calculated according to actual costs. If there is another contract, it must follow the principle of contract priority.
6. Please keep this card and show it to the maintenance team during warranty period.

Shenzhen Megmeet Welding Technology Co.,Ltd
Customer Service Center

Address:Address:3rd Floor, Block C Unisplendour Information Harbor,Langshan Road,
Shenzhen, Guangdong, 518057, China
Customer service hotline: 4006662163

User Notes

1. Warranty scope refers to the body of water cooler.
2. The warranty period is 12 months under the normal use of the warranty period, and water cooler is faulty or damaged. We repair it free of charge.
3. The start time of warranty period is the manufacture date of water cooler. The code number is the only basis to judge the warranty period. The equipment without tank code is treated out of warranty.
 - 4. If any of the following conditions occur during warranty period, a certain maintenance fee will be charged:
 - Failure of water tank caused by not operating according to the user manual;
 - The water cooler is caused by fire, flood, voltage abnormality, etc.;
 - Damage caused when water tank is used for abnormal functions.
5. Service fee is calculated according to actual costs. If there is another contract, it must follow the principle of contract priority.
6. Please keep this card and show it to the maintenance team during warranty period.

Shenzhen Megmeet Welding Technology Co.,Ltd
Customer Service Center

Address:Address:3rd Floor, Block C Unisplendour Information Harbor,Langshan Road,
Shenzhen, Guangdong, 518057, China
Customer service hotline: 4006662163

A decorative graphic consisting of numerous thin, curved lines that originate from the left side of the page and sweep across to the right, creating a sense of motion and depth. The lines are light gray and vary in curvature, some being more pronounced than others.

MEGMEET

Megmeet Electrical Co.,Ltd
Megmeet Welding Technology Co.,Ltd

WWW.megmeet-welding.com

Mail:Welding@megmeet.com

Tel:+86-755-8660 0555

Add:5th Floor,Block B Unisplendour Information Harbor,Langshan Road,shenzhen,
Guangdong,518057,China